



157th NYYC ANNUAL REGATTA

Presented by **ROLEX**



June 10-12, 2011
Newport, Rhode Island

SAILING INSTRUCTIONS

1 RULES

- 1.1 The regatta will be governed by the rules as defined in *The Racing Rules of Sailing* (RRS). Appendix D, Team Racing Rules, will not apply for the Rolex Cup or Great Corinthian Trophy team events.
- 1.2 The prescriptions of US SAILING that are posted at www.yachtscore.com/emenu.cfm?eID=463 on the Annual Regatta website shall apply.
- 1.3 **Offshore Special Regulations:** Minimally all yachts shall comply with the 2010-2011 ISAF Offshore Special Regulations, Category 5 (posted at www.yachtscore.com/emenu.cfm?eID=463) and shall comply with their class rules, where applicable. Yachts that are not normally rigged with lifelines are exempt from Regulation 3.14. In the event of a conflict between these regulations and applicable class rules, the class rules shall apply. The US SAILING prescriptions to the Offshore Special Regulations shall apply except the prescription to Regulation 5.01.1 requiring personnel to wear personal flotation while starting and finishing.
- 1.4 The Protest Committee may impose suitable penalties, other than disqualification, for violations of the ISAF Offshore Special Regulations or other non-Part 2 rules. This changes RRS 64.1.
- 1.5 The 2011 IRC Rules and Regulations shall apply to yachts racing under IRC.
- 1.6 The 2011 PHRF-NB Regulations shall apply to yachts racing under PHRF.
- 1.7 The current class rules shall apply to all yachts racing as a one-design class, except as noted in these sailing instructions.
- 1.8 12 Metre Class only:
The International Twelve Metre Association (ITMA) By-laws and Regulations as of July 2, 2008, and the International Twelve Metre Class Rule as of July 2, 2008, and any subsequent amendments shall apply.

2 ENTRIES

- 2.1 Eligible yachts shall enter by completing online registration with the Organizing Authority. Eligibility requirements for yachts and method of entry are detailed in the Notice of Race.
- 2.2 Team entries for the Rolex Cup and the Great Corinthian Trophy shall be entered on the separate entry forms posted on the Annual Regatta website at www.yachtscore.com/emenu.cfm?eID=463.

3 NOTICES, COMPETITOR INFORMATION AND SIGNALS MADE ASHORE

- 3.1 Notices, including race results, amendments and protest hearing schedules, shall be posted on the Official Notice Board located in the courtyard of the NYYC Sailing Center at Harbour Court. This information may also be posted on the Annual Regatta website (www.nyyc.org/157th-annual-regatta/).
- 3.2 Flag signals will be flown from the flagpole at Harbour Court.
- 3.3 Any change to the sailing instructions will be posted before 0900 on the day it will take effect, except that any change to the schedule of races will be posted by 2000 on the day before it will take effect. Flag "Lima" will be flown to signify such posting.

- 3.4 When Pennant “AP” is displayed ashore, “one minute” is replaced with “not less than one hour” in Race Signal “AP”.
- 3.5 Signals designating the rendezvous locations will be displayed at 0900 on Friday, Saturday and Sunday from the flagpole at Harbour Court. The Race Committee will endeavor to announce the locations as described in SI 6 at that time over VHF Channel 72. The failure to make this announcement or for a yacht to hear this announcement will not be grounds for redress. This changes rule 62.1(a).
- 3.6 After the rendezvous locations and any other regatta announcements have been made, Race Committee Signal Boats will monitor and communicate with their respective fleets on the VHF channels published in SI 4.3.

4 CLASSES AND IDENTIFICATION

- 4.1 The Organizing Authority will divide yachts into classes.
- a) For the Around-the-Island Race on Friday, June 10, classes will be assigned a numeral designation and be designated the GREEN fleet.
 - b) The Swan 42 One-Day Regatta on Friday, June 10, will be designated the BLUE fleet.
 - c) For racing on Saturday and Sunday, classes will be assigned a numeral designation and placed into three fleets (Blue, White or Green).
- 4.2 **Scratch Sheets** - There will be a separate scratch sheet for the Around-the-Island Race on Friday and for each fleet (Blue, White or Green) racing on Saturday & Sunday. Note that a yacht may be in different classes in the different portions of the Annual Regatta. The scratch sheets will be distributed at registration, posted on the Official Notice Board and posted on the regatta website (www.yachtscoring.com/emenu.cfm?eID=463).
- 4.3 **VHF Channels** - The Race Committee VHF channels for each fleet are shown below:
- | | | | |
|------------------------|-------------|----------------------------------|----------------|
| a) Friday, June 10 | Green Fleet | Around-the-Island Race | VHF Channel 71 |
| | Blue Fleet | Swan 42 One-Day Regatta | VHF Channel 72 |
| b) Sat/Sun, June 11-12 | Blue Fleet | IRC 1, IRC 2, IRC 3, Swan 42 | VHF Channel 72 |
| | White Fleet | 12 M, IRC 4, IRC 5, IRC 6, J/105 | VHF Channel 69 |
| | Green Fleet | Classics, 6 M, S Class, PHRF | VHF Channel 71 |
- 4.4 **Backstay Flags** – Each yacht shall display the flag corresponding to her class designation, as shown on the scratch sheet, from her backstay approximately six feet above the deck and above the Rolex flag, from the warning signal of the first class in her fleet until she is no longer racing. Yachts without a permanent backstay shall conspicuously display these flags in an alternate position in the aft part of the yacht.
- 4.5 **Bow Stickers & Flags** - Each yacht shall display the Rolex backstay flag and bow stickers provided at registration while racing. Classics and 12 Metres are not required to apply the bow stickers.

5 SCHEDULE OF RACES

- 5.1 The Around-the-Island Race will be sailed on Friday, June 10, and is open to all eligible yachts. This race is separate from the any racing on Saturday and/or Sunday. Course signals will be made on Friday, June 10 at 1200. Note that the Race Committee **may start the fleet in reverse order** of classes. See SI 9.2 and Addendum A.
- 5.2 The Swan 42 class will sail a ONE-DAY series on Friday, June 10, with drop mark races. See SI Addendum B for details. A Swan 42 may elect to sail in this one-day series or in the IRC class in the Around-the-Island Race.
- 5.3 The TWO-DAY Series will be held on Saturday and Sunday, June 11-12. All races will count in the TWO-DAY Series. The course signals will be made at 1100 for all fleets on Saturday, June 11 and Sunday, June 12.
- 5.4 There will be one NAVIGATOR Race on Saturday, June 11 and one on Sunday, June 12. Each race will be scored separately. The first course signals will be at 1200 each day.
- 5.5 No warning signal shall be made after 1500 on Sunday, June 12.

6 RENDEZVOUS LOCATIONS

Fleet rendezvous locations are listed below and will be designated as described in SI 3.5.

Rhode Island Sound:

- Area “A” - in the vicinity of 160° for 1.2 NM from R “2” QR Whistle marking Brenton Point
- Area “B” - in the vicinity of 120° for 2.5 NM from R “2” QR Whistle marking Brenton Point
- Area “C” - in the vicinity of 225° for 2.0 NM from R “2” QR Whistle marking Brenton Point
- Area “D” - in the vicinity of 200° for 3.5 NM from R “2” QR Whistle marking Brenton Point
- Area “E” - in the vicinity of 165° for 2.5 NM from R “2” QR Whistle marking Brenton Point
- Area “F” - in the vicinity of 150° for 4.5 NM from R “2” QR Whistle marking Brenton Point

Newport Harbor and near Newport Bridge:

- Area “J” - in the vicinity of Mackerel Cove (Conanicut Island opposite Castle Hill)
- Area “K” - between Goat Island and Rose Island
- Area “M” - in the vicinity of R “12” west of Rose Island
- Area “N” - off Coasters Harbor Island (just north of east end of Newport Bridge)
- Area “O” - in the vicinity of Potter Cove (just north of west end of Newport Bridge)

North of Newport Bridge:

- Area “R” - in the vicinity of 200° for 0.5 NM from Halfway Rock
- Area “S” - in the vicinity of RG Nun south of Prudence Island
- Area “T” - in the vicinity of G “7” QG off Quonset Point
- Area “U” - in the vicinity of C “1” northeast of Hope Island.
- Area “V” - in the vicinity of C “5” 290° for 1.0 NM from Pine Hill Point on Prudence Island
- Area “W” - in the vicinity of G “1” 0.9 NM southwest of Hog Island

7 CHECK-IN AND RETIREMENT

- 7.1 Prior to the warning signal for the first race each day, all yachts shall check in with the Race Committee Signal Boat by passing astern on starboard tack and announcing their sail number. The Race Committee will acknowledge by responding with the number heard.
- 7.2 Yachts retiring are requested to inform the Race Committee on their fleet VHF channel or by calling (401) 845-9633.

8 COURSES & MARKS

The courses and marks for each section of the Annual Regatta are described in the SI Addenda as shown:

Friday, June 10	Around-the-Island Race	SI Addendum A
Friday, June 10	Swan 42 One-Day Regatta	SI Addenda B & D
Sat/Sun, June 11-12	Green Fleet (including Navigator Races)	SI Addendum C
Sat/Sun, June 11-12	Blue & White Fleets	SI Addendum D

9 THE START

- 9.1 Races will be started in accordance with rule 26, with classes starting at five-minute intervals.
- 9.2 The order of start for the Around-the-Island Race on Friday, June 10, will be included in the Race Committee’s announcement on VHF Channel 72 at 0900. Classes may start in numerical order or in reverse order. The Race Committee may combine two or more classes into one start by displaying multiple class flags at the Warning Signal. The Race Committee will endeavor to announce the next class(es) to start on VHF Channel 71.
- 9.3 A yacht starting later than 20 minutes after her starting signal will be scored Did Not Start. This changes rule A4.
- 9.4 The starting line will be between a staff displaying an orange flag on the Race Committee Signal Boat and the course side of the port-end starting mark. The Race Committee may deploy a “Keep Off” buoy(s) that shall be considered an integral part of the Race Committee Signal Boat.

9.5 Yachts whose warning signal has not been made shall keep clear of the starting area.

9.6 Sample sequence:

Friday, June 10		Sat/Sun, June 11-12		
<u>Blue</u>	<u>Green</u>	<u>Two-Day</u>	<u>Navigator</u>	
1200	1200	1100	1200	Course Signals
1205	1205	1105	1205	Warning for first class
1206	1206	1106	1206	Preparatory for first class
1210	1210	1110	1210	Start for first class, Warning for second class
	1211	1111	1211	Preparatory for second class
	1215	1115	1215	Start for second class, Warning for third class
	1216	1116	1216	Preparatory for third class
	1220	1120	1220	Start for third class, etc.

10 INDIVIDUAL RECALLS

The Race Committee will endeavor to hail each premature starter over their respective fleet VHF channel. Failure to make such an announcement shall not be grounds for redress. This changes rule 62.1(a).

11 THE FINISH

The finishing line is described in the SI Addenda for each section of the Annual Regatta.

12 GOVERNMENT BUOYS

Government buoys have no required side except when specified as marks of the course. Caution should be exercised for safe navigation.

13 PENALTY SYSTEM

13.1 A yacht that may have broken a rule of Part 2 while racing may take a penalty at the time of the incident as provided below. This changes rule 44.1.

- a) as provided in her class rules, or
- b) by taking a Two-Turns Penalty in accordance with rule 44.2, or
- c) by taking a Scoring Penalty in accordance with rule 44.3.

13.2 A yacht that accepts a Scoring Penalty shall receive additional points equal to 20% of the entrants in that race (rounding 0.5 upward), but shall not have less than two places added to her actual finish position. A yacht's score shall not be worse than Did Not Finish. This changes rule 44.3 (c).

14 TIME LIMIT

14.1 The time limit to sail the course and finish is as follows:

- a) For the Around-the-Island Race courses - five hours.
- b) For a South Bay Racing Chart course - four hours.
- c) For a drop mark course - three hours.

14.2 Yachts failing to finish within 60 minutes of the first yacht in her class to sail the course and finish, or within the time limit, whichever is later, will be scored Did Not Finish (DNF) and scored points as described in SI 16.3. This changes rules 35 and A4.

15 PROTESTS AND REQUESTS FOR REDRESS

15.1 It is requested that yachts intending to protest report both their intention and the yacht being protested to the Race Committee on the fleet VHF channel at the finish of the race.

15.2 Written protests or requests for redress shall be submitted to the Jury secretary in the NYYC Sailing Center as soon as possible, but not later than one hour after the Race Committee Signal Boat for that fleet has docked. The time limit for filing a protest will be posted on the Official Notice Board.

- 15.3 Protest notices will be posted as soon as possible on the Official Notice Board.
- 15.4 Protest hearings will take place at the NYYC Sailing Center as soon as possible after the notices are posted. The Jury will attempt to hear protests in the order of receipt. Representatives of yachts who are parties to a hearing shall remain on call in the vicinity of the protest rooms.
- 15.5 When a yacht has been involved in an incident that may be subject to protest, it is her responsibility to check the protest notices at the end of the protest filing time to see if she is cited in a protest. Failure of any yacht to appear when called for a hearing will be considered by the Jury as grounds for proceeding under rule 63.3(b).
- 15.6 Rule 63.5 is changed by adding, "A protest involving contact may be heard by the Protest Committee even though the requirements of rule 61.1(a) and 61.3 have not been fulfilled."
- 15.7 Breaches of SIs 4.4, 4.5, 7, 9.5 and 18.2 will not be grounds for a protest by a yacht. This changes rule 60.1(a).
- 15.8 A violation of SI 18.2 will be considered "a gross breach of a *rule*" under rule 69.1(a).
- 15.9 On the last scheduled day of racing only, a written request for reopening a hearing shall be delivered to the Jury Secretary:
- Within the protest time limit if the requesting party was informed of the Protest Committee's decision on the previous day; or
 - No later than 30 minutes after the requesting party was informed of the Protest Committee's decision on that day; or
 - If no races are held on the last scheduled day of racing, within one hour after racing has been abandoned.
- This changes rule 66.
- 15.10 On the last scheduled day of racing, a request for redress based on a Protest Committee decision shall be delivered in writing no later than 30 minutes after the decision was posted. This changes rule 62.2.

16 SCORING

- 16.1 A yacht's series score will be the total of her race scores. There will be no drop race. This changes rule A2.
- 16.2 One race is required to be completed to constitute a series.
- 16.3 Yachts that have started and fail to finish within the time limit for any reason, shall, without a hearing, be scored by the Race Committee with points equal to the number of yachts in her class that have sailed the course and finished within the time limit, plus two. This changes rule A4.1, A4.2, and A5.
- 16.4 Teams competing for team trophies will be scored in accordance with the Notice of Race.

17 PRIZES

Prizes will be awarded as described in the notice of race.

18 NOTES

- 18.1 Competitors are reminded that Narragansett Bay and its approaches are considered restricted channels for commercial traffic and other vessels restricted in their ability to maneuver. Competitors must comply with the government right-of-way rules when in proximity to commercial or privileged marine traffic.
- 18.2 In the event there is racing in Narragansett Bay, competitors should be aware of heightened security around the Navy base in Newport just to the north of the Newport Jamestown Bridge. The area to the east of a line defined by a series of white buoys marking the Newport Security Zone along the coast of the Naval Facilities from Coasters Harbor to the breakwater at the north end of Coddington Cove shall rank as an obstruction. Yachts shall not enter this area. A Navy patrol boat monitors the area and vessels navigating in the Exclusionary Zone may face action by Coast Guard and Naval authorities.
- 18.3 All times herein are Eastern Daylight times. Bearings are in degrees magnetic and are approximate. Distances used herein are expressed in nautical miles (when not otherwise defined) and are approximate.

18.4 Newport Tides

Day	Date	Low Tide	High Tide
Friday	June 10	0846	1541
Saturday	June 11	0946	1642
Sunday	June 12	1041	1743

18.5 For further information please contact:

New York Yacht Club, Harbour Court

5 Halidon Avenue

Newport, RI 02840

Tel: 401-845-9633

Fax: 401-846-3303

Email: sailingoffice@nyyc.org

Website: www.nyyc.org/157th-annual-regatta/

157th NYYC Annual Regatta presented by Rolex

EVENT COMMITTEE

Margaret D. Comfort, Chair

Robert C. Towse, Jr., Commodore, NYYC
Thomas J. Harrington, Vice Commodore, NYYC
A. Rives Potts, Jr., Rear Commodore, NYYC
Philip A. Lotz, Chairman, NYYC Sailing Committee

RACE COMMITTEE

John. L. Myles, Jr., Chair

BLUE FLEET
John. L. Myles, Jr., PRO
John Mendez, APRO

David K. Elwell, Jr.
Ingrid M. Flynn
Richard R. Gumpert
Barbara Kapinska
Daniel Kelly
Martin J. Kelly, MD
Blakely Kimbrough
Barbara A. Moloney
Thomas E. Moloney
Jonathan H. Nye
Eric P. Richards
Allegra M. Torrey

WHITE FLEET
Roger W. Fortier, Jr., PRO
Kevin Keogh, APRO

Allen H. Breed
Lee Chrisman
Alton J. Evans, Jr.
Thomas K. Flynn
Karin Nye
Jack R. Orben
Ellyn Coyle Osmond
Patrick Schoonveld
Joan Towse

GREEN FLEET
Clare J. Gesualdo - PRO
Samuel Wakeman, APRO

Robert Armes
Michael D. F. Deck, MD
Lawrence Gotch
Timothy M. James
Pauline Mendez
Dorothy B. Myles
Steve Williams

Elizabeth Condon, Scorer
John I. Condon, Jr., Scorer
Rowena Dery, Scorer

PROTEST COMMITTEE

Patricia A. O'Donnell, Chair

Peter A. Gerard
Richard R. Gumpert
Ronald A. Hopkins
Gregory R. Kiely
John D. Osmond III, MD
Samuel W. Wakeman
Catherine Kennedy - Secretary
Judy McLennan - Secretary



SAILING INSTRUCTIONS

Addendum A – AROUND-THE-ISLAND RACE

Friday, June 10

1 ORDER OF START

- 1.1 The order of start for the Around-the-Island Race on Friday, June 10, will be included in the Race Committee's announcement on VHF Channel 72 at 0900. Classes may start in numerical order or in reverse order. The Race Committee may combine two or more classes into one start by displaying multiple class flags at the Warning Signal. The Race Committee will endeavor to announce the next class(es) to start on VHF Channel 71.
- 1.2 The starting mark will be a YELLOW tetrahedron buoy.

2 COURSES FOR AROUND-THE-ISLAND RACE

- 2.1 The Race Committee will use VHF channel 71 for the Around-the-Island Race on Friday, June 10.
- 2.2 The flag(s) designating the course to be sailed will be displayed at Course Signals. The Race Committee will endeavor to announce the designated courses over VHF channel 71. Failure to make such an announcement shall not be grounds for redress. This changes rule 62.1(a).
- 2.3 Special Mark "U"
 - a) The Race Committee may add a new first mark to any course by displaying flag "U" above a Green or Red flag on a separate pole.
 - b) Mark "U" is to be rounded either to STARBOARD (Green flag below "U") or to PORT (Red flag below "U").
 - c) The bearing and distance to Mark "U" will be displayed on a whiteboard.
 - d) Mark "U" will be an 8' ORANGE tetrahedron buoy.
- 2.4 **Course "J"**, clockwise around Conanicut Island:
 - RG "NR" Bell 650 yards SW of Beavertail Point to starboard
 - The center span of the Jamestown Verrazano Bridge
 - C "5" 1,250 yards NW of Conanicut Point to starboard
 - R "2" Fl R 4 Sec Bell 900 yards NE of Conanicut Point to starboard
 - The center span of the Newport Jamestown Bridge
 - Pass to the west of R "12" off Rose Island
 - Finish off Fort Adams (see SI 15.2)
- 2.5 **Course "JR"** - if Flag "R" is flown beneath Flag "J", the Around Conanicut Island race shall be sailed in the reverse direction (counter-clockwise), with the above rounding marks passed to port, finishing off Fort Adams.
- 2.6 For the purposes of rule 32.2(c), the center spans of the Jamestown Verrazano Bridge and the Newport Jamestown Bridge shall be considered gates.
- 2.7 The finishing line for the Around-the-Island Race Courses will be between a staff displaying an orange flag on a Race Committee Boat and the finishing mark, which will be an 8' orange tetrahedron buoy. The finishing line will be located approximately 0.25 NM north of the Fl R 6 sec Horn "2" on the northern point of Fort Adams.
- 2.8 In fog at the finish, the Race Committee Boat may ring a bell rapidly, for approximately 5 seconds, at intervals. The same Race Committee Boat may or may not start and finish each race.

SAILING INSTRUCTIONS

Addendum B – SWAN 42 ONE-DAY REGATTA

Friday, June 10

The Swan 42 One-Day Regatta on Friday, June 10, will use the sailing instructions for the 157th Annual Regatta as modified below:

1 COURSES

Courses are described in SI Addendum D – Drop Mark Courses

2 SCHEDULE OF RACES

- 2.1 The Swan 42 class will sail a ONE-DAY series on Friday, June 10, with drop mark races.
- 2.2 The Race Committee intends to run practice starts beginning at 1100.
- 2.3 The course signals will be made at 1200 and the warning signal at 1205 for the first race of the day.
- 2.4 No warning signal shall be made after 1530.

3 SCORING

- 3.1 A yacht's series score will be the total of her race scores. There will be no drop race. This changes rule A2.
- 3.2 One race is required to be completed to constitute a series.
- 3.3 The Swan 42 One-Day Regatta is a separate regatta from the Annual Regatta and results from each regatta will be scored separately.
- 3.4 Yachts entered in the Series to determine the NYYC Invitational Cup entry shall count all scores from this regatta, the Annual Regatta and the 2011 Swan 42 Nationals. Scoring shall be done in accordance with the Notice of Series.

SAILING INSTRUCTIONS

Addendum C – GREEN FLEET

Saturday-Sunday, June 11-12

The Green Fleet, including Classics, 6M, Herreshoff S Class and the Navigator Race classes (PHRF, PHRF NS) will race on course(s) using the South Bay Race Chart as follows:

1 COURSES USING SOUTH BAY RACING CHART

Special courses will be designated using buoys as described on the 2009-2012 South Bay Race Chart provided at registration. Do not use older versions of the Race Chart. (Note: designated courses from the back of the South Bay Race Chart will not be used.)

- a) The Race Committee will list the marks on a white board in the order to be rounded and the required side to leave the mark using the designations on the 2009-2012 South Bay Race Chart.
- b) **Newport Bridge** – Due to ongoing painting, yachts shall pass through the **center span only** for any course passing under the Newport Bridge.
- c) Special Mark “U”
 - The Race Committee may add a first mark to any course by displaying flag “U”.
 - If “U” is used, there will be either a Green or Red flag displayed below “U” to designate the direction to be rounded. Mark “U” is to be rounded either to STARBOARD (Green flag below “U”), or to PORT (Red flag below “U”).
 - Special Mark “U” will be positioned approximately 0.5 NM to windward from the RC signal boat.
 - Mark “U” will be a YELLOW tetrahedron buoy.
- d) The course will be:
 - Start
 - Special Mark “U” if used
 - Round the marks in the designated order leaving each mark to the designated side
 - Finish
- e) The finishing mark will be on the opposite side of the Race Committee Signal Boat from the starting mark.

2 MARKS

- 2.1 Mark “U”, if used, will be a YELLOW tetrahedron buoy. The starting mark will be a YELLOW tetrahedron buoy. The finishing mark will be an ORANGE tetrahedron buoy.
- 2.2 Special NYYC Temporary Inflatable Race Marks 16 and 17 as designated on the 2009-2012 South Bay Race Chart, if used, will be ORANGE tetrahedron buoys.

SAILING INSTRUCTIONS

Addendum D – DROP MARK RACES

Saturday-Sunday, June 11-12

The Swan 42 One-Day Regatta (on Friday) and the Blue and White fleets (on Sat/Sun), including IRC, Swan 42, 12M and J/105 will race on courses as described below:

1 COURSES FOR DROP MARK RACES

1.1 Course Diagrams

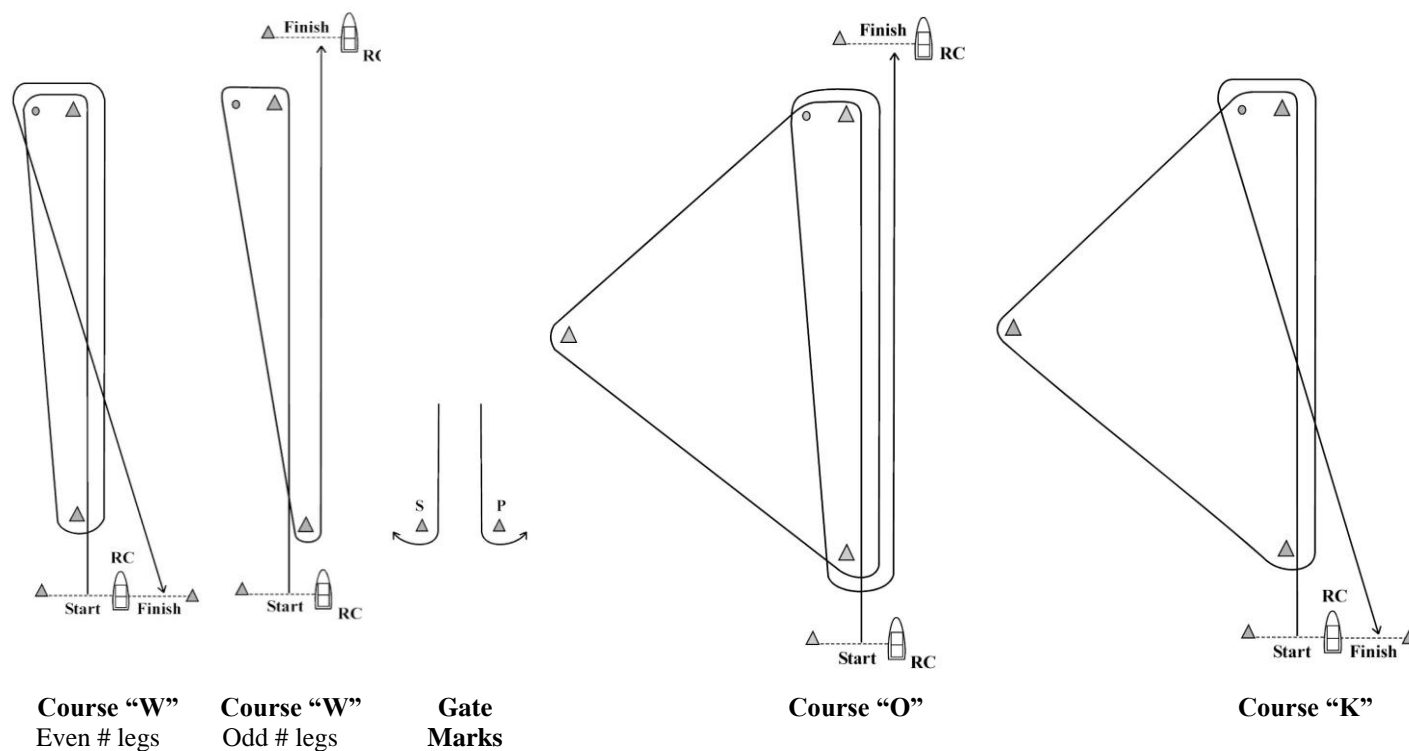

- 1.2 **Course "W"** is a Windward/Leeward course with a windward offset mark. A numeral pennant indicating the number of **LEGS** to be raced will be flown beneath Flag "W". The distance between the windward mark and the offset mark shall not count as a leg for the purposes of indicating the number of legs.
- 1.3 **Course "O"** is a Triangle/Windward/Leeward/Windward course.
- 1.4 **Course "K"** is a Triangle/Windward/Leeward course.
- 1.5 The leeward mark for Courses "W", "O", and "K" will be an inflatable mark(s) set approximately 0.10 NM to windward of the starting line.
- 1.6 The course designation, distance and bearing to the windward mark will be signaled using flags displayed on poles. The course designation will be flown forward, followed by the three numeral pennants designating the magnetic bearing to the first mark, followed by the two numeral pennants designating distance (nautical miles and tenths) to the first mark.
- 1.7 Marks, including the windward offset mark, shall be rounded in order and left to port, except that a gate, when used, shall be rounded as described rule 28.1(c).
- 1.8 There will be a windward offset mark adjacent to the windward mark for all drop mark courses.

- 1.9 This instruction applies to the **BLUE FLEET** only:
- For course “W” with an even number of legs, the Race Committee may set a long windward mark and a short windward mark.
 - The distance displayed will be to the SHORT windward mark. The long windward mark will be on the same bearing at a distance of 1.0 NM beyond the short windward mark.
 - The long windward will have a black band and there will be no offset mark.
 - If flag “U” is displayed with the course signals, that class will sail to the LONG windward mark. If flag “U” is NOT displayed with the course signals, that class will sail to the SHORT windward mark.

This changes the diagrams in Addendum D 1.1, 1.2, 1.7, 1.8 and 2.3.

2 MARKS FOR COURSES “W”, “O”, and “K”:

2.1 Marks will be inflatable tetrahedron buoys as follows:

<u>Fleet</u>	<u>Original marks</u>	<u>Starting/Finishing</u>	<u>Change marks</u>
BLUE	Yellow 8’	Orange 5’	Orange 8’
WHITE	Orange 8’	Yellow 5’	Yellow 8’

2.2 Offset marks will be small round orange buoys.

3 COURSE CHANGE

- 3.1 In addition to the requirements in rule 33, the Race Committee will attempt to announce any course change on their respective fleet VHF channel. Failure to make such an announcement shall not be grounds for redress. This changes rule 62.1(a).
- 3.2 The new mark will be a different color (orange or yellow) from the original mark as described in SI Addendum D 2.1. For a subsequent change, the new mark will be the same as the original mark.

4 THE FINISH

- 4.1 The finishing line will be between a staff displaying an orange flag on a Race Committee Boat and the finishing mark.
- For Course “W”, with an odd number of legs, and Course “O”, the finish line will be located approximately 0.1 NM to windward of the windward mark.
 - For Course “W”, with an even number of legs, and Course “K”, the finish line will be located approximately 0.1 NM to leeward of the leeward mark and the finishing mark will be on the opposite side of the Race Committee Signal Boat from the starting mark. See diagrams in SI Addendum D 1.1.
- 4.2 If a subsequent race is to be sailed, the finish line Race Committee Boat will fly Pennant “Second Substitute” with the Blue “On-Station” signal at the finish. If a Class Flag is displayed below Pennant “Second Substitute” the subsequent race is for that class(es) only.
- 4.3 In fog at the finish, the Race Committee Boat may ring a bell rapidly, for approximately 5 seconds, at intervals. The same Race Committee Boat may or may not start and finish each race.